

- Series VZGG
- Series VZVA
- Series VZAL
- Local displays TD8250



POSITIVE DISPLACEMENT FLOW SENSORS



Positive displacement flow sensors

Gearwheel type flow sensors record volume flows of liquids with both high and changing viscosities. The high-precision sensors work according to the displacement principle. The high resolution combined with reliable measurement accuracy make the sensors especially useful for applications involving the measurement of small and very small volumes.

In principle, the measurement accuracy is increased for high viscosities. Conversely, the measurement accuracy is lower with a viscosity of less than 10 mm²/s. Due to their construction, gearwheel type flow sensors require a certain lubricity of the fluid being measured. Operation with non-lubricating media, e.g. water, is not possible.

Applications

- Consumption measurement
- Control of filling operations
- Dosage of oils and chemicals
- Flow measurement of paints and varnishes
- Ratio control of polyol and isocyanate

Principle of operation

A very precisely adjusted gear pair within the casing forms the measuring element. The inflowing medium causes the gear pair to rotate. The rotary motion is scanned by contactless sensors. Since each individual tooth generates a pulse, this results in a very high resolution. Consequently, even the smallest volumes can be measured or dosed precisely.

The measurement unit contains two pick-offs that are circumferentially offset by ¼ of a tooth pitch to generate a 2 channel flow-proportional frequency signal. Suitable processing of the signal provides an greater resolution and the option to identify the flow direction.

The maximum pressure drop should not exceed 16 bar. This limits the measurement range of high viscosity media (see pressure drop diagrams). Basically, the measurement accuracy increases with increase in viscosity of the media.

- 1 Housing bottom
- 2 Housing cover
- 3 Gear wheels
- 4 Pre-amplifier
- 5 Connection plug
- 6 Pick-offs
- 7 Bearing
- 8 Measurement chamber

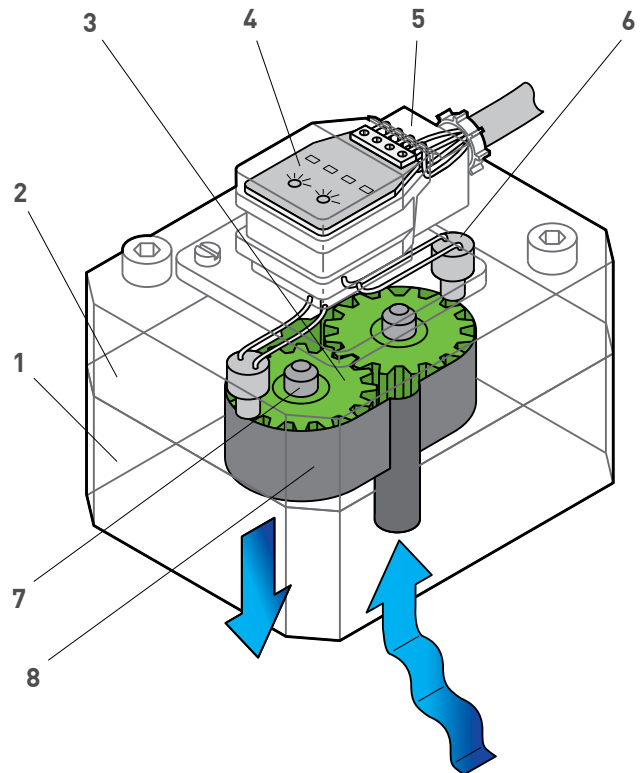

Overview of performance features of the VZGG / VZVA / VZAL

	VZGG / VZVA	VZAL
Housing	Ductile iron or stainless steel	Aluminium
Viscosity of medium	1...100 000 mm ² /s	1...4000 mm ² /s (depending on the model)
Temperature of medium	-30...120 °C (standard)	-10...80 °C
Measuring accuracy	±0.3 % of reading	±1... 3 % of reading
Sizes	8	4
Process connection	Via subplate with lateral female thread connection	Direct female thread

Additional performance features of the VZGG / VZVA

- The measuring volume per pulse determines the size, e.g. 0.4 cm³/pulse for VZ 0.4...-S
- HT version for temperatures up to 150 °C with thermally insulated preamplifier (option)
- Intrinsically safe explosion-proof versions available in accordance with ATEX (max. medium temperature 80 °C)
- Variety of casing and sealing materials, meaning they can be universally used for different measurement media
- Standard process connection via connecting plates, so they can be replaced quickly without lengthy interruptions to the process
- Other bearings for special requirements on request

Additional performance features of the VZAL

- Standard process connections
- Output signal: pulse signal



Positive displacement flow sensors

Series VZGG, VZVA



Type	VZ0.025	VZ0.04	VZ0.1	VZ0.2	VZ0.4	VZ1	VZ3	VZ5
Size	0.025	0.04	0.1	0.2	0.4	1	3	5
Start of gear wheel rotation [l/min]	0.001	0.004	0.008	0.01	0.01	0.02	0.03	0.04
Measuring range* [l/min]	0.008...2	0.02...4	0.04...8	0.16...16	0.2...40	0.4...80	0.6...160	1...250
Geometric gear volume [cm ³]	0.025	0.04	0.1	0.245	0.4	1.036	3	5.222
Measuring volume [ml/Pulse]	0.025	0.04	0.1	0.245	0.4	1.036	3	5.222
Resolution [Pulse/l]	40 000	25 000	10 000	4081.63	2500	965.25	333.33	191.5

* For media with high viscosity the measuring range is reduced.

The max. pressure drop shouldn't exceeded 16 bar (see pressure drop diagrams).

Technical data			
Measuring accuracy	±0.3 % of reading (21 mm ² /s)		
Repeatability	0.05 % for same conditions		
Viscosity of medium	1...100 000 mm ² /s		
Pressure rating	→ VZ 0.025... to VZ 1... -max. 400 bar → VZ 3... to VZ 5... -max. 315 bar → Higher pressure rating on request		
Medium temperature range (depends on sealing material)	FKM	FEP	EPDM
→ Standard	-15...120 °C	-30...120 °C	-30...120 °C
→ Without preamplifier (for TD8250)	0...60 °C	0...60 °C	0...60 °C
→ High temperature	-15...150 °C	-30...130 °C	-30...130 °C
→ Ex version	-15...80 °C	-30...80 °C	-30...80 °C
Ambient temperature range (depends on sealing material)	FKM	FEP	EPDM
	-15...80 °C	-30...80 °C	-30...80 °C
Process connection	Via subplate with lateral female thread connection		
Power supply	12...30 VDC / max. 90 mA		
Electrical connection	Via standard socket		
Degree of protection EN 60529	IP65		
Output signal	2-channel, squarewave, pulse duty ratio 1:1, PNP		

Typical pressure drop VZ0,025

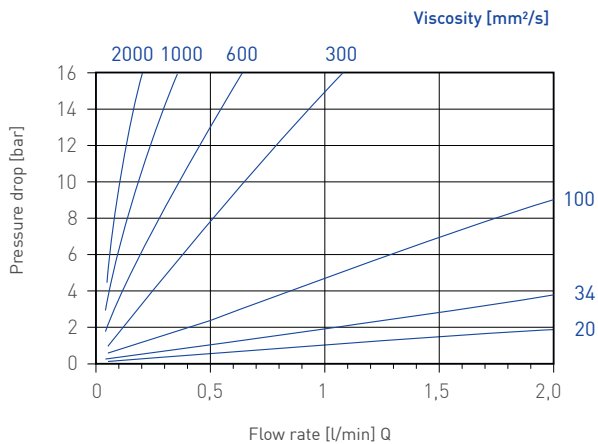

Typical pressure drop VZ0,04

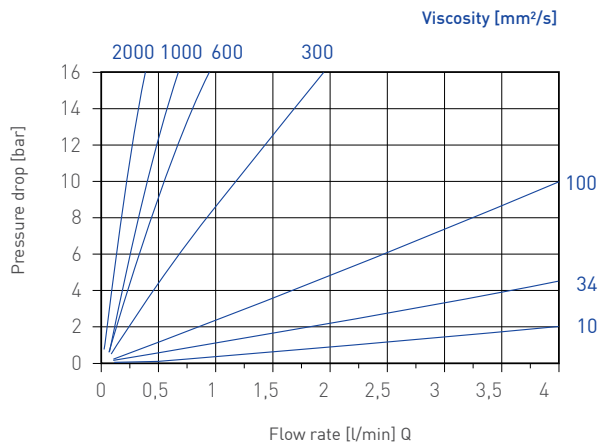

Typical pressure drop VZ0,1

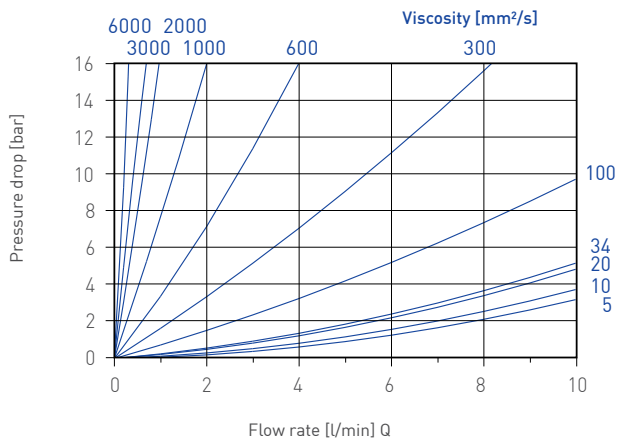

Typical pressure drop VZ0,2

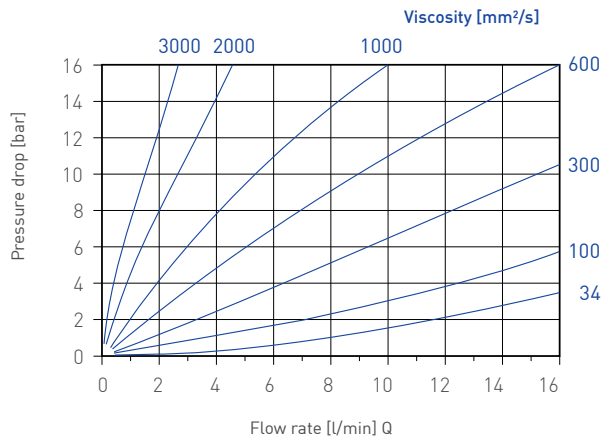

Typical pressure drop VZ0,4

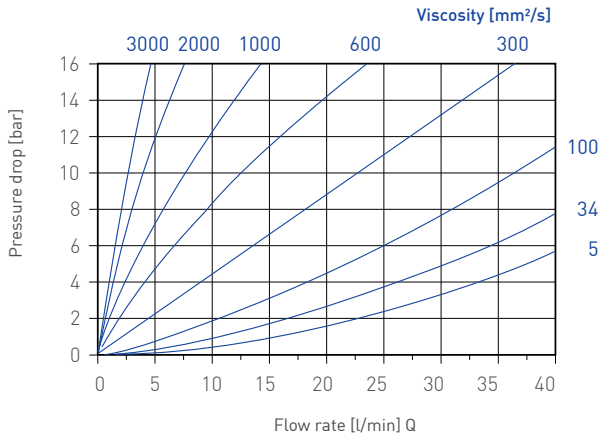

Typical pressure drop VZ1

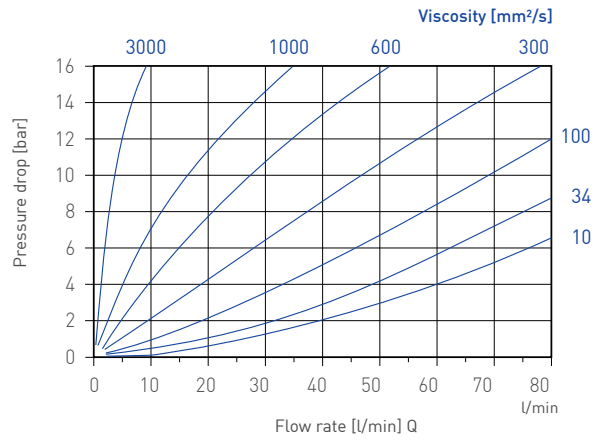

Typical pressure drop VZ3

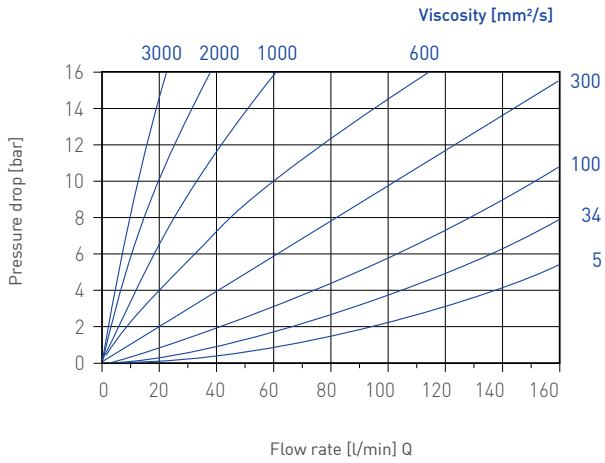

Typical pressure drop VZ5

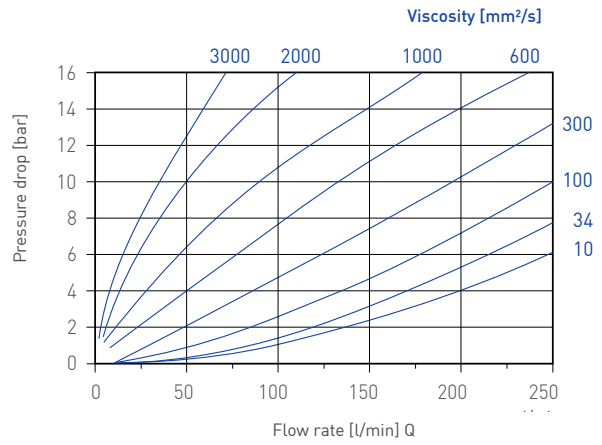

VZGG

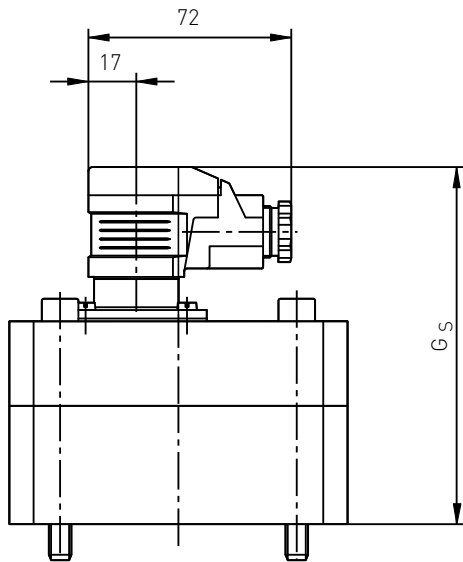

Standard version and Ex version

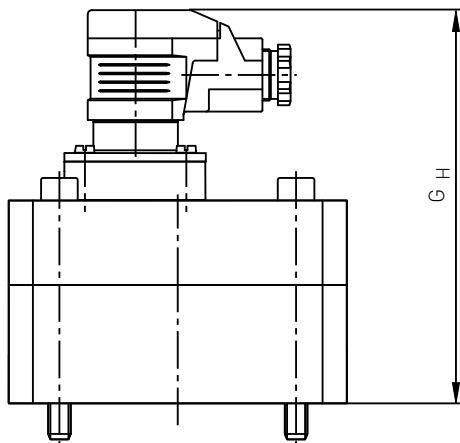
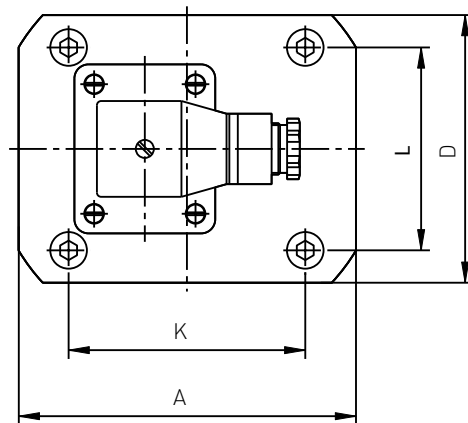

High temperature version

Material	
Housing	Ductile iron EN-GJS-400-15
Gear wheels	Steel 1.7139
Ball bearings	100CR6 / 1.3505
Seals	Standard: FKM Option: EPDM, FEP

Type	VZ0.025GG	VZ0.04GG	VZ0.1GG	VZ0.2GG	VZ0.4GG	VZ1GG	VZ3GG	VZ5GG
A [mm]	85	85	85	85	100	120	170	170
D [mm]	60	60	60	60	90	95	120	120
GS [mm]	101	107	116	108	114	123	140	156
GH [mm]	114	120	129	121	127	136	153	169
Weight [kg]	1.8	2	2.3	2	3.7	5.2	9	13

VZVA

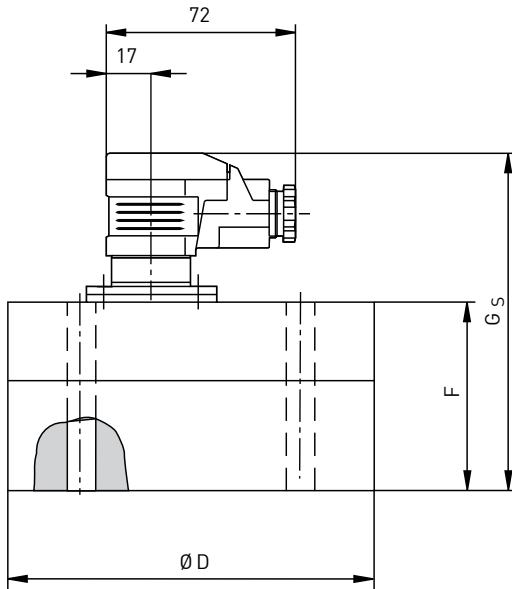

Standard version and Ex version

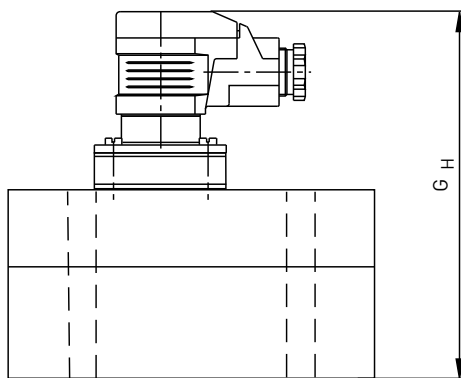
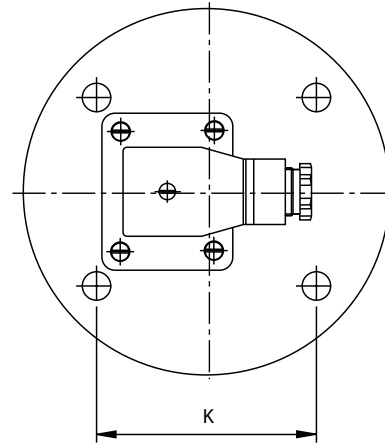

High temperature version

Material	
Housing	Stainless steel 1.4404
Gear wheels	Stainless steel 1.4462
Ball bearings	X105CrMo17 / 1.4125
Seals	Standard: FKM Option: EPDM, FEP

Type	VZ0.025VA	VZ0.04VA	VZ0.1VA	VZ0.2VA	VZ1VA	VZ3VA	VZ5VA
D [mm]	94	94	94	94	124	170	170
F [mm]	55	56	65	57	72	89	105
GS [mm]	106	107	116	108	123	140	156
GH [mm]	119	120	129	121	136	153	169
Weight [kg]	3	3	3	3.1	7	15.9	18.7

Subplates for VZGG

For type	VZ0.025GG / VZ0.04GG / VZ0.1GG / VZ0.2GG	VZ0.4GG	VZ1GG	VZ3GG / VZ5GG
A [mm]	85	100	100	160
B [mm]	90	110	120	165
C [mm]	35	37	37	80
c [mm]	0.7	0.7	0.7	1
d [mm]	25	29	29	42
E [mm]	65	86	80	140
e	G $\frac{3}{8}$	G $\frac{1}{2}$	G $\frac{1}{2}$	G 1
F [mm]	76	96	106	145
f [mm]	13	15	15	19
G [mm]	7	7	7	9
H [mm]	11	11	11	15
J [mm]	7	7	7	9
K [mm]	70	80	84	46
L [mm]	40	38	72	95
M [mm]	20	34	35	50
N [mm]	6.5	16	12	25
P [mm]	M 6/14t	M 8/18t	M 8/18t	M 12/24t
R [mm]	17	18.5	17.5	28
Weight [kg]	1.8	2.7	2.9	14
Material	Ductile iron EN-GJL-250	Ductile iron EN-GJL-400-15	Ductile iron EN-GJL-250	Ductile iron EN-GJL-250

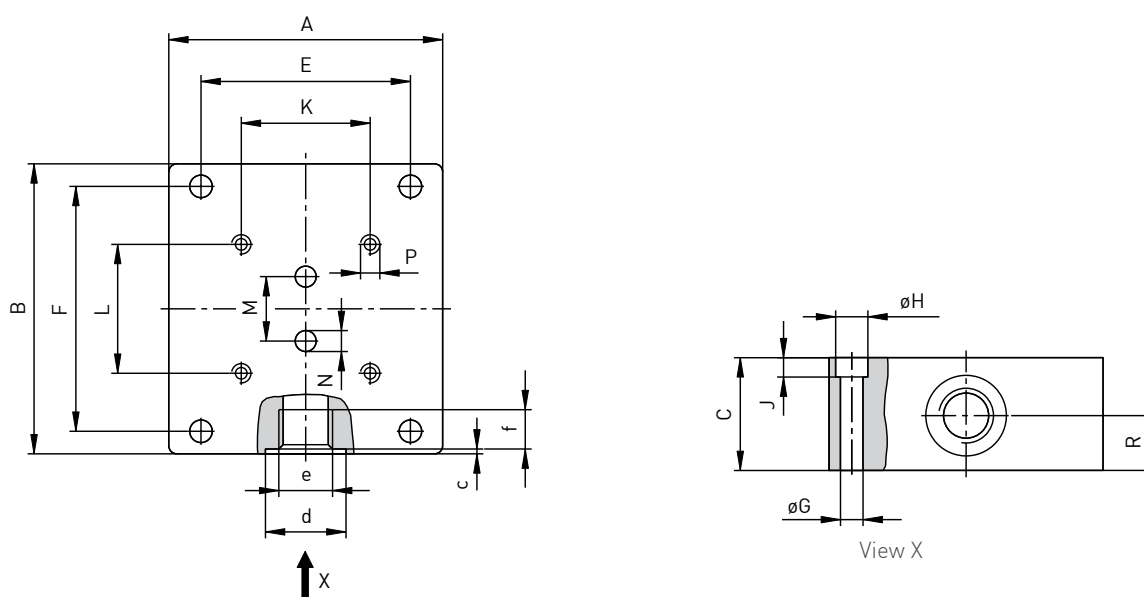

Subplates for VZVA

For type	VZ0.025VA / VZ0.04VA / VZ0.1VA / VZ0.2VA	VZ1VA	VZ3VA / VZ5VA
B [mm]	85	116	158
C [mm]	35	37	80
D [mm]	94	124	170
E [mm]	75	100	140
e	G $\frac{3}{8}$	G $\frac{1}{2}$	G1
f [mm]	13	15	19
G [mm]	7	9	9
H [mm]	11	15	15
J [mm]	7	9	9
K [mm]	70	84	46
L [mm]	40	72	95
M [mm]	20	35	50
N [mm]	6.5	12	25
P [mm]	M 6/14t	M 8/18t	M 12/24t
R [mm]	18	19.5	52
Weight [kg]	1.7	3.2	13.9
Material	Stainless steel 1.4404		

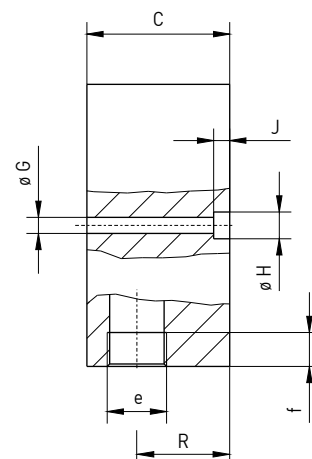
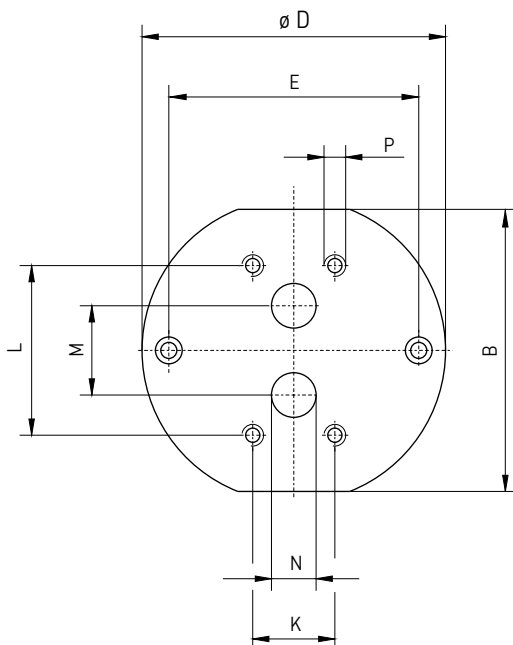

Order code		Example → VZ0025	GG	V	3	2	I	00S	
Type	Size								
VZ0.025	0.025	VZ0025							
VZ0.04	0.04	VZ004							
VZ0.1	0.1	VZ010							
VZ0.2	0.2	VZ020							
VZ0.4	0.4 (only ductile iron)	VZ040							
VZ1	1	VZ100							
VZ3	3	VZ300							
VZ5	5	VZ500							
Material									
Ductile iron			GG						
Stainless steel			VA						
Seals									
FKM				V					
EPDM				E					
FEP				P					
Power supply									
12...30 VDC						3			
Process connection									
With subplates							2		
Direct (only for stainless steel)							1		
Preamplifier									
Integrated								I	
Without preamplifier, for TD8250 (not for Ex-version)								K	
Isolated for high temperature version (not for Ex-version)								E	
Version									
Standard									00S
Ex-version									10S

Order code	Example → AP004	GG	0380S
Subplates appropriate to			
VZ0.025 / VZ0.04 / VZ0.1 / VZ0.2	AP004		0380S
VZ0.4 (only ductile iron)	AP040		0120S
VZ1	AP100		0120S
VZ3 / VZ5	AP500		1000S
Material			
Ductile iron		GG	
Stainless steel		VA	



Positive displacement flow sensors

Series VZAL

Type VZ0.2AL



Type VZ2AL



Technical data				
Type	VZ 0.04AL	VZ0.2AL	VZ2AL	VZ5AL
Size	0.04	0.2	2	5
Measuring range*	0.02...4 l/min	0.16...16 l/min	1...65 l/min	1...200 l/min
Viscosity of medium	20...4000 mm ² /s	1...3000 mm ² /s	20...4000 mm ² /s	20...4000 mm ² /s
Measuring accuracy	±2 % of reading	±1 % of reading	±2.5 % of reading	±1 % of reading
Pressure rating	Max. 200 bar	Max. 160 bar	Max. 160 bar	Max. 80 bar
Pressure peaks	Max. 240 bar	Max. 200 bar	Max. 200 bar	Max. 100 bar
Medium temperature range	-10...80 °C integrated preamplifier 0...60 °C without preamplifier (for TD8250)			
Thread connection	G1/4	G3/8	G3/4	G 1
Weight	0.5 kg	0.7 kg	1.9 kg	6 kg
Volume per pulse	0.04 cm ³	0.245 cm ³	2 cm ³	5.222 cm ³
Number of output channels	1	2	1	1
Output signal	<ul style="list-style-type: none"> → Signal shape → Pulse rate → Resolution 			
	Square wave, pulse signal, PNP, pulse duty ratio 1:1 ±15 % 25000 pulses/l 0.04 ml/pulse	Square wave, pulse signal, PNP, pulse duty ratio 1:1 ±15 % 4082 pulses/l 0.245 ml/pulse	Square wave, pulse signal, PNP, pulse duty ratio 1:1 ±15 % 500 pulses/l 2 ml/pulse	Square wave, pulse signal, PNP, pulse duty ratio 1:1 ±15 % 191.5 pulses/l 5.2 ml/pulse
Indication	Cable socket with one LED for pulse signal	Cable socket with two LED for pulse signal (two channels)	Cable socket with one LED for pulse signal	Cable socket with one LED for pulse signal
Electrical connection	Plug connector incl. cable socket			
Power supply	12...30 V DC reverse polarity protection			
Power input	0.6 W short circuit proof	0.9 W short circuit proof	0.6 W short circuit proof	0.6 W short circuit proof
Degree of protection EN 60529	IP65			

* For media with high viscosity the measuring range is reduced.
The max. pressure drop shouldn't exceeded 16 bar (see pressure drop diagrams).

Typical pressure drop VZ0,04AL

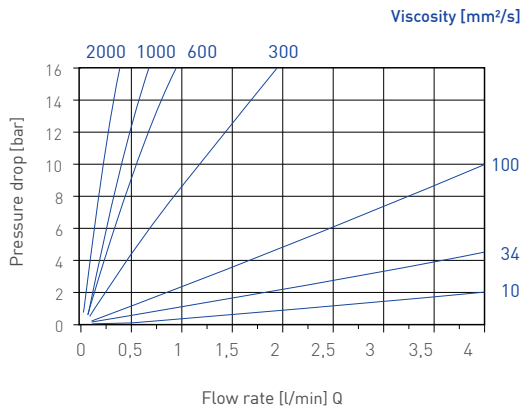

Typical pressure drop VZ0,2AL

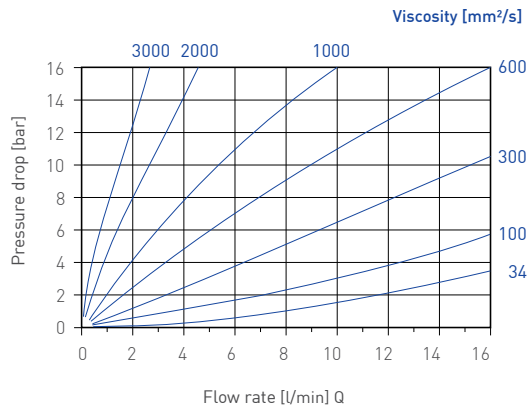

Typical pressure drop VZ2AL

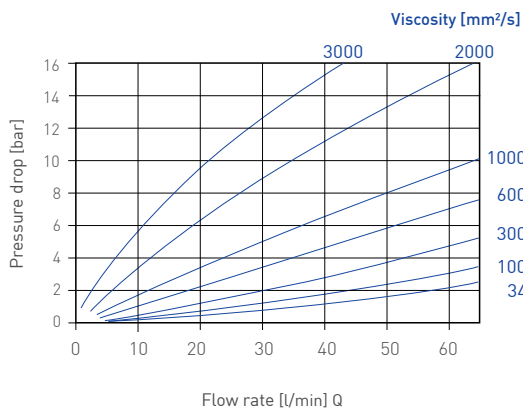

Typical pressure drop VZ5AL

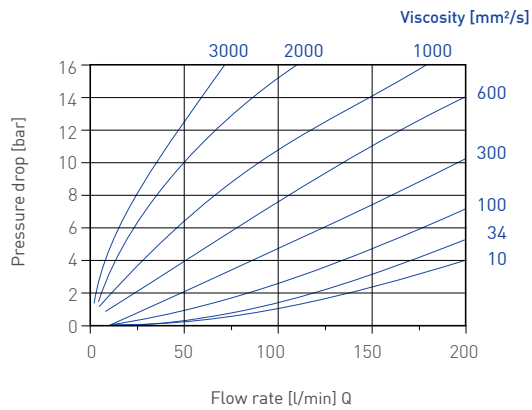

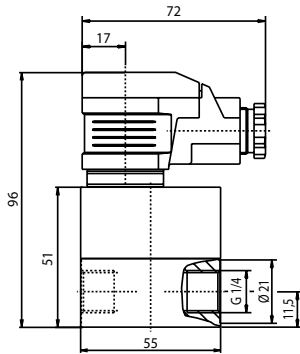
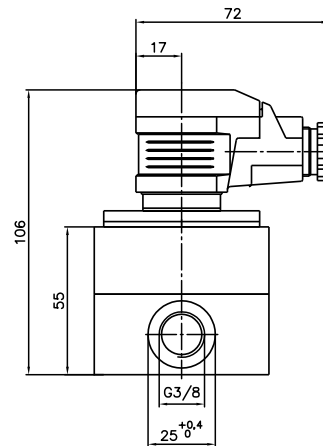
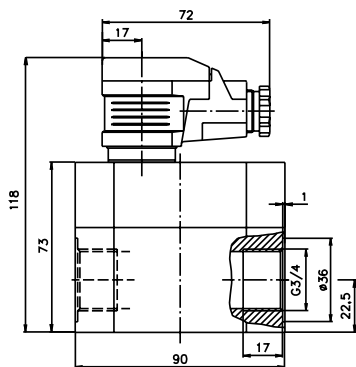
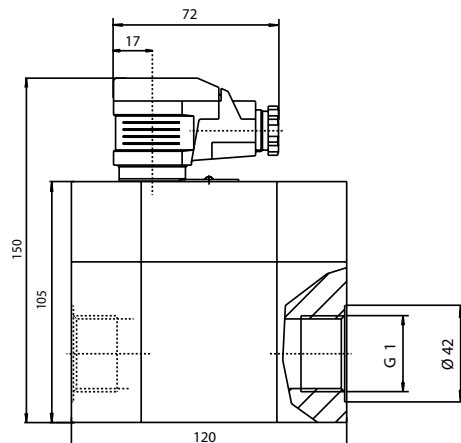
VZ0.04AL

VZ0.2AL

VZ2AL

VZ5AL

Material

Type	VZ0.04AL	VZ0.2AL	VZ2AL	VZ5AL
Housing	Aluminium, gold-colour anodised	Aluminium, gold-colour anodised	Aluminium AlMgSi F30 (hard coated)	Aluminium AlMgSi F30 (hard coated)
Gear wheels	Stainless steel 1.4462	Steel 16 MnCr5, hardened	Steel 1.7139	Steel 1.7139
Bearings	Ball bearings	Ball bearings stainless steel	Sleeve bearings (P10)	Ball bearings
Seals	FKM	FKM	FKM	FKM

Order code

Example → VZ004ALV31 I00S

Type	Size		
VZ0.04AL	0,04	VZ004ALV31	
VZ0.2AL	0,2	VZ020ALV31	
VZ2AL	2	VZ200ALV31	
VZ5AL	5	VZ500ALV31	
Pre-amplifier			
Integrated			I00S
Without pre-amplifier (for TD8250)			K00S

Accessories

Local displays, series TD8250

The local display TD8250 is simply fitted between the plug connector plug and the cable socket of VZGG, VZVA or VAL positive displacement flow sensors. It is programmable via two buttons which are located behind the front panel. It can be set to display either the actual flow rate or the total volume (counter function), as required. The TD8250 is available in three different output signal versions:

- Pulse output (2-channel, depending on flow sensor)
- Analogue output 0(4)...20 mA
- Two alarm contacts

It is also easy to retrofit onto existing flow sensors. To do this, merely remove the amplifier board from the cable socket.

Technical data	
Signal input	Pulse signal from flow sensor
Programming	Via 2 buttons, data retention on power off
Display	Four-digit LED display, red, 7.6 mm high
Power supply	19...28 VDC, optional 10...19 VDC
Current consumption	Max. 120 mA
Ambient temperature	0...60 °C
Storage temperature	-25...85 °C
Output signals	Pulse output (2-channel, depending on flow sensor) or analogue output 0(4)...20 mA or 2 alarm contacts max. 24 VDC / 1 A
Housing	Aluminium, 60 x 35 x 60 (W x H x D) without plug connector
Weight	Approx. 120 g
Degree of protection EN 60529	IP65
Electrical connection	Plug connector DIN EN 175301-803-A, 4 pin



Order code	Example → ED825F	60
Output signals		
Pulse output	ED825F	
Analogue output 0(4)...20 mA	ED825A	
Two alarm contacts	ED825R	
Power supply		
19...28 VDC (standard)		60
10...19 VDC (option)		50

Switch amplifier, series K-130

The switch amplifier K-130 serves as an interface between electrical signals of the hazardous areas to the safe areas.

The input signals of positive displacement flow sensors in in Ex-version are transmitted through transistor contacts. The input-, output- and power supply circuits are safe galvanic separated.



This unit is approved as associated apparatus.

Type K-130

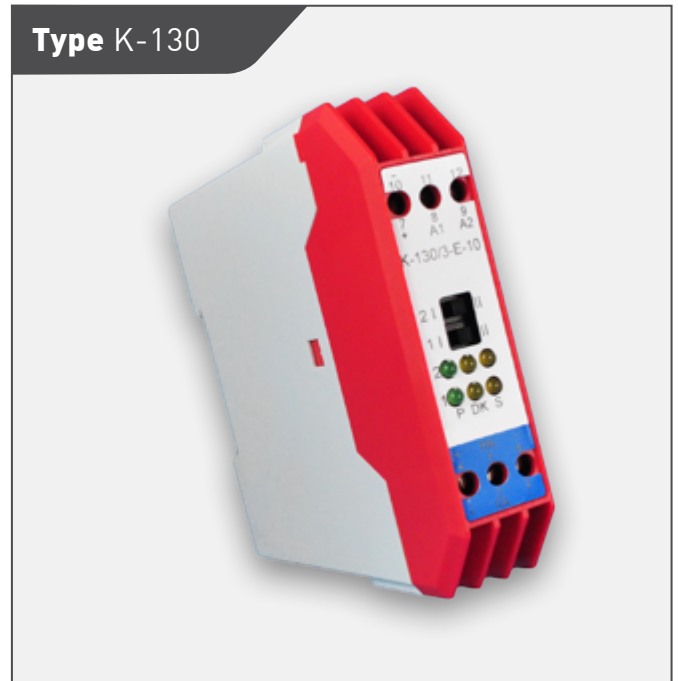

Technical data	
Temperature ranges	
→ Ambient	-25...60 °C
→ Storage	-25...85 °C
Humidity	Max. 75 % RH
Housing	For assembly rail setup DIN EN 50022
Dimensions	114.5 mm x 22.5 mm x 99 mm (H x W x D)
Declaration of conformity	94/9/EG: CE 0158
Field of application	EX II (2) G D, [EEEx ia] II C
EC-type examination	PTB 03 ATEX 2094 X
Electrical data	
Signal input	2 channel frequency signal of positive displacement flow sensors in Ex-version
→ Switching points	0 ≤ 9 mA 1 ≥ 12 mA
→ Open circuit voltage	10 V
→ Short circuit current	82 mA
Signal output	2 channel, open collector
Power supply	24 V AC/DC (±20 %)
Power consumption DC	3.6 W
Mode selection	2x switch
Displays	6x LED, each Channel power indication, switch status and wire monitoring
Order code	
	K-130-ATEX